

# **Gallatin Gateway County Water & Sewer District**

## **PUBLIC MEETING**

**Date: Monday, December 13, 2021**

**Time: 6:30 PM**

**Place: Gallatin Gateway Fire Department, 320 Webb St. Gallatin Gateway, MT**

A teleconference bridge for public input can be joined at **1-605-562-8400** and

using **Participant Access Code 1286503** or by using the following web link:

**<http://hello.freeconference.com/conf/call/1286503>**

### **AGENDA**

#### **I. Public Participation on Non-Agenda Items<sup>1</sup>**

#### **II. Conflict of Interest Disclosure<sup>2</sup>**

#### **III. Approval of Minutes**

- A.** Approval of Meeting Minutes for November 08, 2021

#### **IV. Old Business**

- A.** Discussion with APE representatives:

APE representatives presented an overview of their experience and overall plan to provide the services of a General Manager and financial/billing administration to GGSWD. This was followed by a thorough discussion of how specific operations would be handled and how the transition will be managed.

- B.** ADA compliant website within two to four weeks. The site would be hosted, supported and secured by Streamline with free, unlimited archiving and automatic updates. Unlimited training and technical support are also included in the monthly fee.

Director Amend moved to contract with Streamline to Develop a new website for GGSWD and Director Fox seconded the motion. It was approved unanimously.

- C.** Update on Phiel Acquisitions' refund of PIC charges

No update occurred since the District's Council has not gotten back to the District on this matter. President Border will follow-up again with the District's Council.

#### **V. New Business**

- A.** Establish requirements and fee structure to disconnect from GGWSW service (Big Sky Water and Sewer Example attached.)

- B.** Connection application fee for force main (\$500) vs. gravity main (\$200) currently \$500 for both.

- C.** Lot 4A of Minor Subdivision 56B - Genesis Engineering Pre-Design Application

- D. Discussion and Decision on refund of Pfeil Acquisitions (Glampground) PIC charges.  
District council recommendations attached.

## **VI. Reports of Officers, Standing Committees and Special Committees**

- A. General Manager's Report - Concerns with the septicity of flow to Four Corners
- B. Existing Will Serve Agreements
- C. Gateway Village Report (Director Fox)

## **VII. Adjourn**

<sup>1</sup>The opportunity for members of the public to comment on District matters which are not on the agenda. Time limits may be imposed at the discretion of the President.

<sup>2</sup>An opportunity for Board members to disclose any potential, perceived or real conflict of interest on any item on the agenda or for any District business.

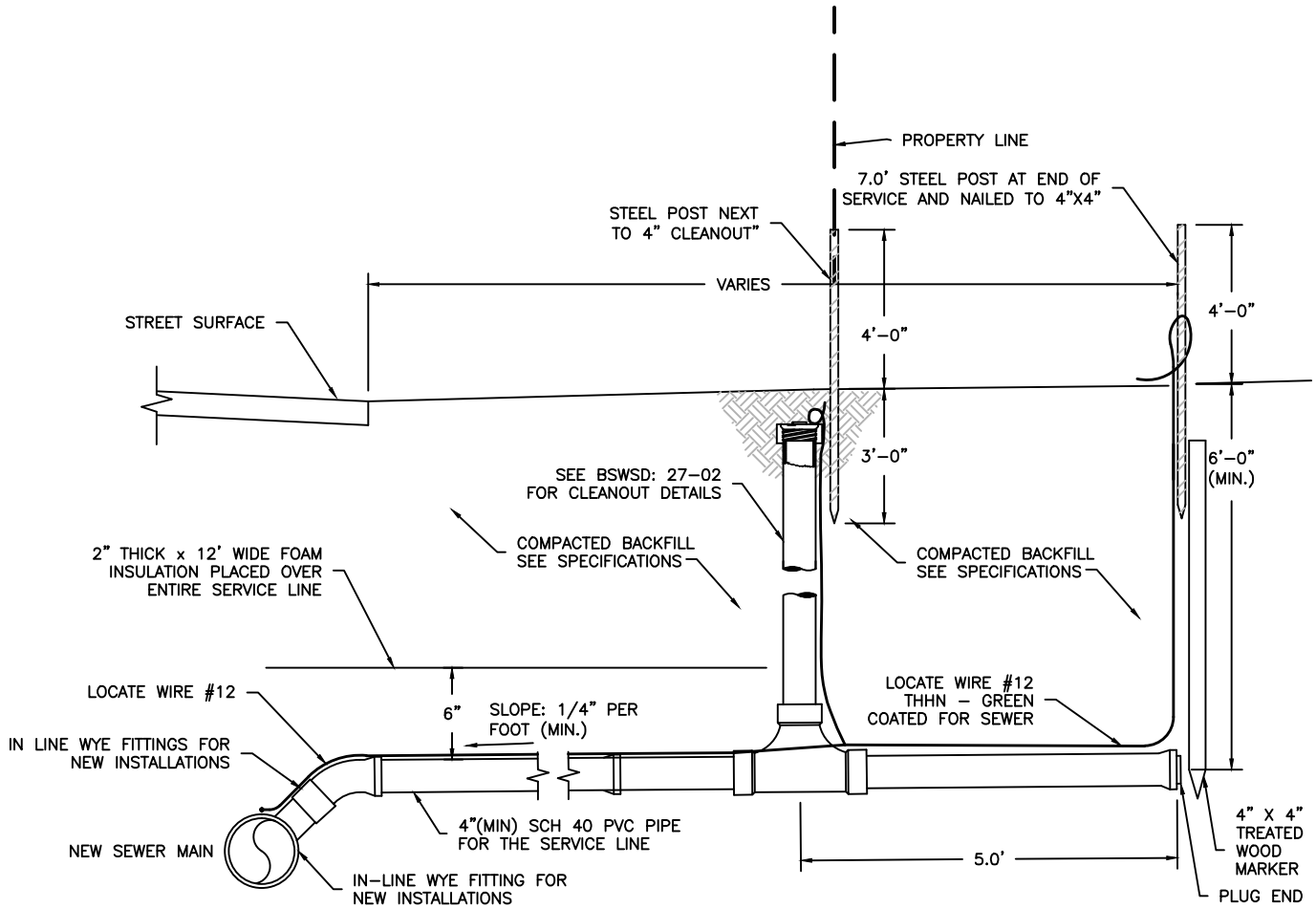

NEW INSTALLATION

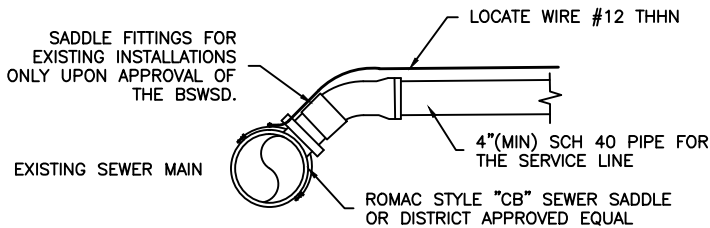

CONNECTING TO EXISTING SEWER MAIN

- NOTE:**
- WHERE SERVICE LINE IS BURIED UNDER AREAS TRAVELLED BY VEHICLES OR PEDESTRIAN PLACE 2" THICK BY 24" WIDE STROFOAM INSULATION.

DETAIL NO.:

BSWSD:  
27-01

**BIG SKY WSD 363  
STANDARD DRAWING**

SCALE:  
NONE

SANITARY SEWER SERVICE  
LINE

DATE: FEBRUARY 2010  
LAST REVISION: MAY 9, 2010  
CROSS REFERENCE WITH: N/A

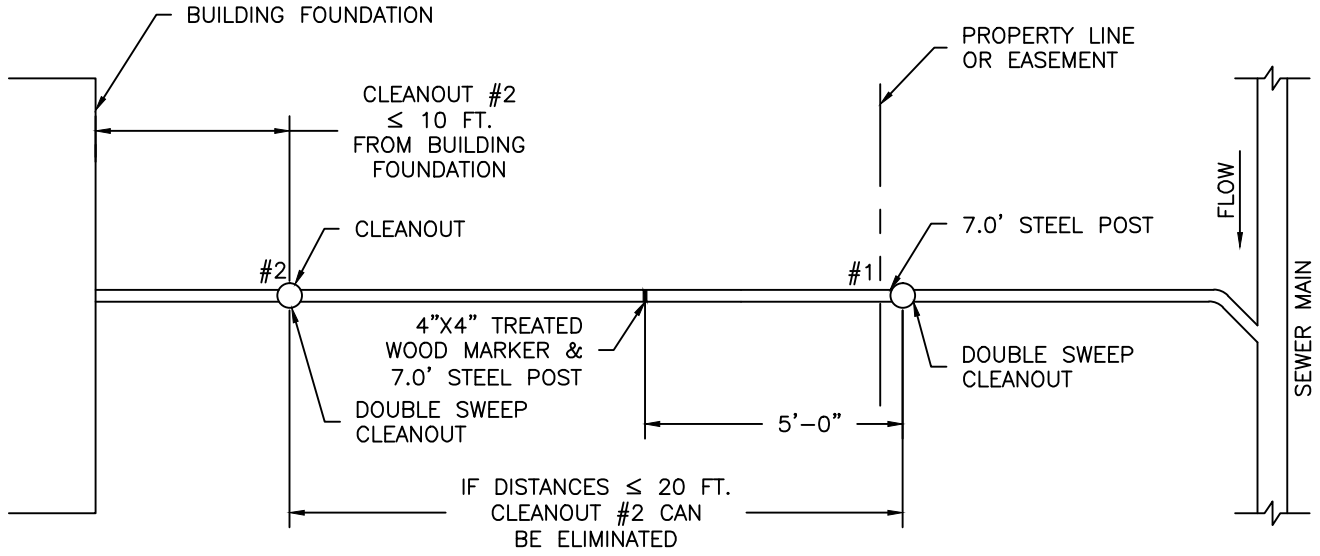

**NOTES:**

1. CLEANOUTS EVERY 100 FEET.
2. ALL CLEANOUTS NEED TO BE READILY ACCESSIBLE AT THE COMPLETION OF THE PROJECT.

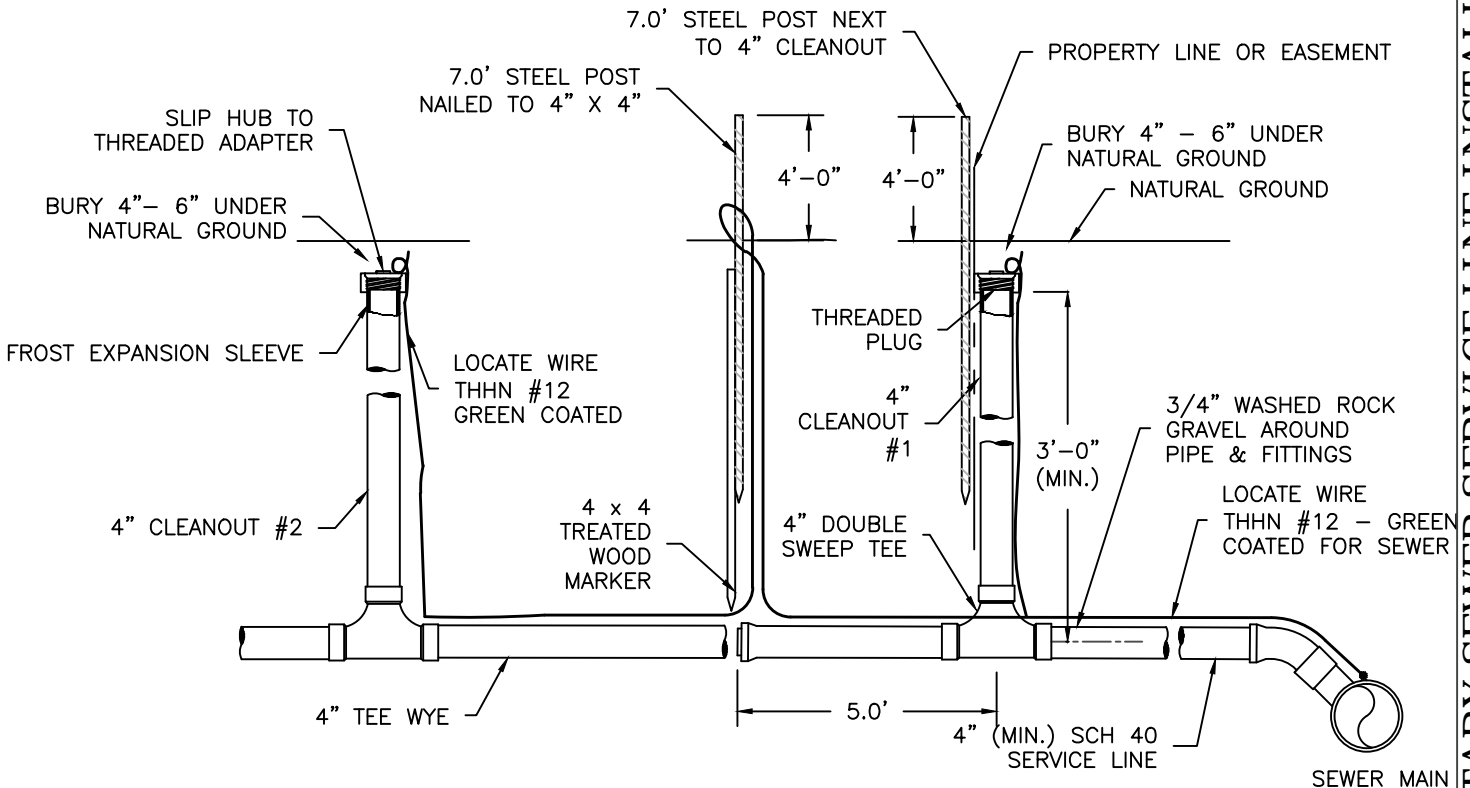

**NOTES:**

1. SEE DETAIL NO: BSWSD: 27-13 FOR INSULATION REQUIREMENTS.

<p>DETAIL NO.:  BSWSD: 27-02</p>	<p><b>BIG SKY WSD 363 STANDARD DRAWING</b></p>	<p>SCALE: NONE</p>	<p>TYPICAL SANITARY SEWER SERVICE LINE INSTALLATION W/ CLEANOUTS</p>	<p>DATE: FEBRUARY 2010 LAST REVISION: MAY 4, 2010 CROSS REFERENCE WITH: N/A</p>
--	--	------------------------	--	---

**From:** Susan Swimley swimley@swimleylaw.com

**Subject:** GGWSD - Pheil Acquisitions, LLC

**Date:** November 29, 2021 at 4:30 PM

**To:** Cary Fox cary@gatewaywsd.com, Ted Border tborder@gatewaywsd.com, Maralee Sullivan msullivan@gatewaywsd.com, Erin Arnold, Chief Dpty CA Erin.Arnold@gallatin.mt.gov

**Cc:** utilities@advpump.com

SS

Good Afternoon:

As you are all aware, the Gallatin Gateway County Water issued a will serve letter for the Riverbend Glamping Resort / Pheil Acquisitions in late 2019. On September 14, 2020, prematurely and without clear authorization, a former general manager signed an annexation agreement. The service agreement contained erroneous language such as “submitted a petition for annexation” and “The District considered the petition and agreed to grant the petition up the following terms:...” No petition for annexation had been submitted and the Board had not agreed to provide service based upon a submitted petition for annexation. Based upon the erroneous agreement for annexation, the former general manager signed a service agreement which did not contain all necessary information required by the agreement.

In October of 2020, after receipt of a petition for annexation, my office provided a proposed ordinance, which, if passed, would have annexed the real property but left the ownership of the sewer lines to the landowner. Pheil Acquisitions appeared the Board meeting and did not agree to the terms of annexation. The Board tabled the consideration of the annexation in order to investigate the costs of insurance for pollution to the Gallatin River, in the event a river/water event broke the sewer line.

More than a year has passed with no action. It is my commendation that the Board deny the petition for annexation as the terms requested by Pheil Acquisitions are onerous on the balance of the properties in the District as the demand that the District take ownership of the raw sewer lines under the Gallatin River shift the liability of any potential pollution to the District and away from the owner generating the sewer. Then please return the Pheil Acquisitions funds.

Susan B. Swimley  
Attorney and Counselor at Law  
1807 West Dickerson, Unit B  
Bozeman MT 59715  
406 -586-5544 (telephone)  
406-586-3130 (fax)

The information contained in this communication may be confidential; is intended for the use of the recipient(s) above; and may be legally privileged. If the reader of this message is not the intended recipient, you are hereby notified that any viewing, dissemination, distribution, or copying of this communication, or any of its contents, is strictly prohibited. If you receive this communication in error, please return it to the sender immediately and delete the original and any copy from your computer system. If you have concerns about this message, please contact the sender.